

# Sliding Door Operator Besam SL500

ASSA ABLOY

ASSA ABLOY Entrance Systems

The global leader in  
door opening solutions



The modular Besam SL500 enables upgrades and add-ons when you want to move your business forward

### Sustainable Entrances

With additional sealing (Besam TightSeal), sustainable drive mode, intelligent opening width depending on traffic, inner- and outer door air locking, and timer settings - be assured that your entrance suits your people flow as well as your environmental footprint.

### Safety First

To permit safe passage between closing doors, the doors reverse if an obstruction is detected then resume their interrupted movement at low speed to check if it has disappeared. If an obstruction is detected between opening doors and surrounding walls or interior fittings, the door immediately stops and then closes after a time delay. The door's speed and force can be customized to optimize safety. For optimally safe operation and convenience of your people flow, use a monitored Besam presence detection system.

### Technical specifications

Power supply	100 V AC -10% to 240 V AC +10%; 50/60 Hz
Power consumption	max. 250 W
Besam SL500-2 without break-out	200 kg/door leaf
Besam SL500-2 with break-out	100 kg/door leaf
Besam SL500-R/L without break-out	240 kg
Besam SL500-R/L with break-out	100 kg
Clear opening width (COW)	
Besam SL500-2	900 – 3000 mm
Besam SL500-R/L	900 – 3000 mm
Hold open time	0 – 60 s
Ambient temperature	-20°C to +50°
Relative humidity (non-condensing)	Max. 85%

### Security and Monitoring

Choose your security level by adding different features. Unwanted guests are not an issue for the Besam SL500 as its locking devices and operation mode selector can be tailored to meet your security needs during opening as well as business closing hours. Inter air locking facilities.

Ensure you are one step ahead of break-downs via maintenance indicators and automated diagnostics, or let us take care of your maintenance via ASSA ABLOY Entrance Systems tailored Maintenance programs.

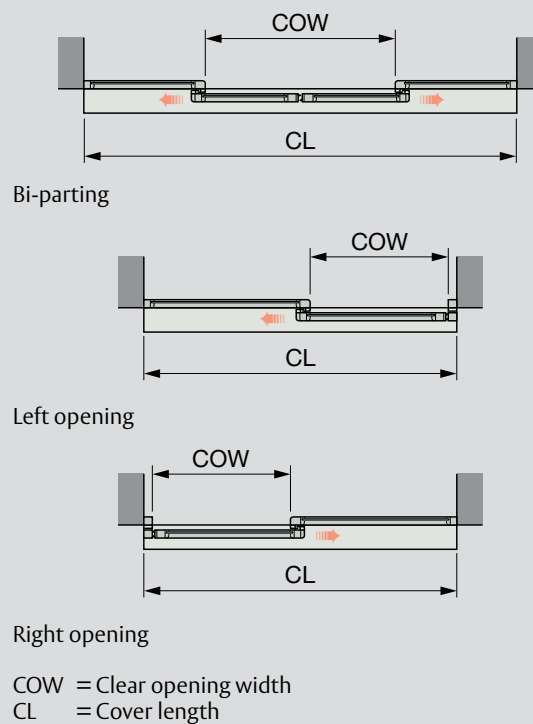
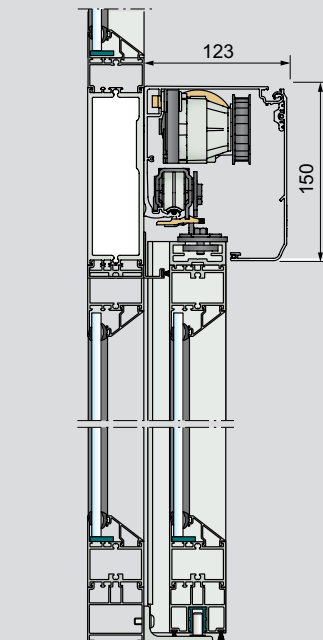

### Appealing Aesthetics

The Besam SL500 further improves the aesthetics of your automated entrance system. With the operator's sleek design, state-of-the-art operation mode selectors, minimum amount of operational parts as well as smooth and quiet operation - the Besam SL500 ensures both convenience and appeal to pedestrians.

### Models

**Besam SL500-2** - 2 leaves, bi-parting, with or without break-out

**Besam SL500-R/L** - 1 leaf, single-slide, right or left opening, with or without break-out

### Standard equipment

Cover Support beam with transmission

Electronic control unit with plug-in connections and power supply

### Accessories and Options

Cover:

Clear anodized aluminium (other anodizing optional)  
Paint finished in colour RAL 9010 (other RAL paint finishes optional)

Door adaptor for doors up to 65 mm thickness made by others

Traffic-controlled opening width

Synchronizing of two operators

Operation mode selectors

Electronic emergency opening or closing unit

Break-out unit

Emergency button

Besam motion and presence sensors

Electrical locking devices

Interlocking between two operators

Key switch

Besam Automatic Door systems

This equipment should be installed, regularly inspected, maintained and serviced by trained and authorized personnel. Preventive maintenance plans are highly recommended for a proper and safe operation. Talk to your ASSA ABLOY Entrance Systems representative to learn more about our service offering!